

AMENDMENT NO. 5 (01/2020)

TO

**AIS-113: Code of Practice for Type Approval of Trailers / Semi-trailers of categories T2, T3 and T4 being towed by Motor Vehicles of categories N2 and N3**

**1. Page 1/50, clause No. 1.0**

**Substitute following scope for existing scope of the standard**

**“1.0 SCOPE**

This standard lays down the requirements applicable to Trailers of Category T2, T3, T4 and vehicle carrier trailers, used to transport goods, being towed by motor vehicles of N2 and N3 category.

- Note:** (1) Trailers of category T1 and T5 are not covered in this standard.  
(2) The scope of this standard does not cover design aspects and is restricted to type approval purpose only.  
(3) The scope of the standard does not cover special purpose trailers, vehicle carriers (other than vehicle carrier trailers) and trailers towed by Category M vehicles.”

**2. Page 13/50, clause No. 8.3.1**

**Substitute following text and figures for existing text and figure 3 of clause 8.3.1**

Tractor-Trailer combination shall comply with the maneuverability requirement, as laid down under clause 5.0 of IS12222:2011 as amended from time to time. Figure 3 shall be referred for TCCD limit. In case of vehicle carrier trailers, length of canopy shall not exceed 1000 mm in forward longitudinal direction; front taper shall not exceed 30 degrees and shall have sufficient clearance above the driver cabin for safe operation on roads.

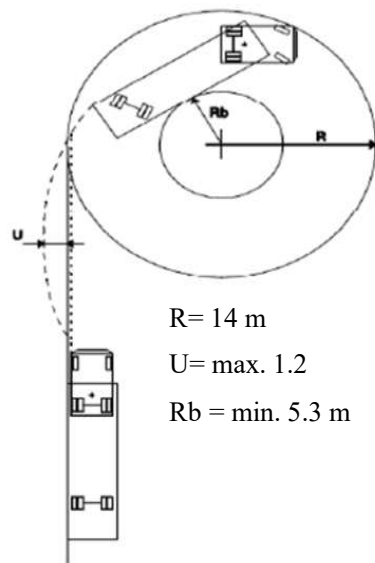

**Figure-3:  
Vehicle Maneuverability**

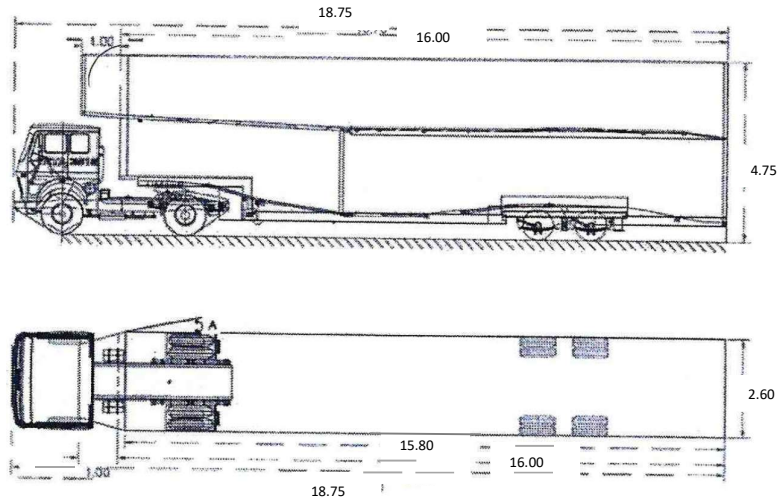

**Figure 4 (for purpose of this standard)**  
**Canopy with an “overhang” of 1m, and a front taper “A”**

PRINTED BY  
 THE AUTOMOTIVE RESEARCH ASSOCIATION OF INDIA  
 P. B. NO. 832, PUNE 411 004  
 ON BEHALF OF  
 AUTOMOTIVE INDUSTRY STANDARDS COMMITTEE  
 UNDER  
 CENTRAL MOTOR VEHICLES RULES - TECHNICAL STANDING COMMITTEE  
 SET-UP BY  
 MINISTRY OF ROAD TRANSPORT & HIGHWAYS  
 (DEPARTMENT OF ROAD TRANSPORT & HIGHWAYS)  
 GOVERNMENT OF INDIA

17<sup>th</sup> January 2020